



Ampcontrol Allenwest

TYPE AW2000 SINGLE DRIVE STARTERS (FOR GROUP I MINING)



Certified to EN Standards

Up to 3,600 V, or 7,200 V, 50/60 Hz

Up to 750 A Isolator

Up to 630 A Vacuum Contactor

Choice of Cable Terminations

Wide Overcurrent Range

Earth Leakage Protection

Earth Lockout

Available as free standing or custom designed switchboards



ISO 9001
Certificate No FM21000

INTRODUCTION

The AW2000 Single Drive Motor Starter range is a development from our highly successful AW2000 Multi-Contactor Load Centre Range.

AW2000 Single Drive Motor Starters are available as free standing units with optional facilities to cable the incoming supply through to another unit, or arranged for assembling in switchboard formation by means of inter-trunk busbar boxes.

Alternatively, complete switchboards can be supplied for permanent installations.

General Application

Type AW2000 Single Drive Motor Starters are available for use on various 3 phase supply systems, nominally up to 3.3 kV, or alternatively up to 6.6 kV, 50/60 Hertz.



AW2000 6.6 kV Single Drive Motor Starter

Applications

AW2000 Single Drive Motor Starters are suitable for direct-on-line ventilation, pumping and conveyor drives.

Conveyors which have ancillary drives to control fluid couplings, loop control, brakes etc are more suitable for control by AW2000 Load Centres.

Construction

The AW2000 3300 V Single Drive Motor Starter enclosure is a modular design, fabricated from sheet steel, and may be supplied as a free standing unit, or assembled in a switchboard formation with intertrunks. This arrangement is suitable for on site assembly and can be extended to suit variations to system applications.

Alternatively factory pre-assembled switchboards can be supplied for permanent installations.

Flameproof Certification

The equipment is certified flameproof and suitable for use in gassy coal mines (Group I).

It is normally manufactured and certified in compliance with EN 50 014 and EN 50 018 flameproof standards.

Allowance has been made in the design to meet the approval standards of most other global regions.

Additional sealing for a higher degree of IP56 ingress protection can be provided.

Non- Flameproof Variation

The AW2000 range can be supplied as non-flameproof. Construction is similar, but the enclosures are not machined to the same tolerance, or subjected to hydraulic pressure tests.

This is suitable for other below ground mining environments which are non-gassy, but never the less, wish to have the other built in safety qualities combined with ruggedness of equipment designed primarily for the coal mining industry.

Isolator

The isolating switch is located in an increased safety, IP54 compartment as provided for in EN 50 014 within the main enclosure. Live line indication of the incoming and outgoing side of the isolator is provided.

The isolator is mechanically interlocked with the front cover and must be in the OFF position before the cover can be opened.

The increased safety compartment is fully shrouded to prevent contact with incoming live components to the isolator. The isolator shrouding is painted red.

Various types of isolator can be provided.

These are suitably rated for the supply voltage and application specified. Typically these include :

On-Off,
Forward-Off-Reverse,
Forward-Off-Reverse-Test

Most are available as off-load or on-load switches.

Isolators can be fitted with with auxiliary switches to provide interlock , test, or position monitoring of isolator.

Vacuum Contactors

The lower portion of the main compartment contains the vacuum contactor, control, monitoring and protection equipment.

Vacuum contactors are mounted on a withdrawable chassis to allow ease of access for inspection and maintenance checks.

Vacuum contactors are suitably rated for the supply voltage and application.

Typically these include :



3.3 kV 300 A Allenwest Wallacetown, Vacutac Vacuum Contactor

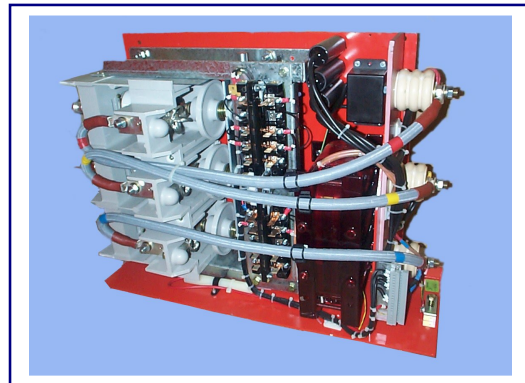

6.6 kV 630 A Alsthom Vacuum Contactor

Indication

Live-Line indication is provided in the main compartment.

Analogue or bar meters are used for voltage or current indication.

Lamps are provided to indicate circuit status and fault finding.

Control

Various methods of control are available to suit special applications which include microprocessor, electro-mechanical or relays that interface with PLC systems if required.



Typical Control Panel

Earth Fault Protection

The following data is typical. Actual ranges and settings are provided to suit variations of application :-

Overcurrent	2.5 – 304 A
Short circuit	6, 8 or 10 x overcurrent setting
Earth Leakage	from 100 mA to 5 amp
Earth Lockout	from 220 kilohm to 10 kilohm

Overcurrent Protection

Overcurrent protection is provided to suit the application and according to the specification.

It can be CT operated thermal over current protection, or if a wide range of protection is required, electronic protection.

The latter can have a selector switch allowing a choice of up to 12 settings from 2.5 –300 A.

The overload unit operates when the monitored current exceeds the selected full load current level. Time to trip is based on an inverse time characteristic.

Overcurrent protection can be either self resetting, or latching.

Indication is provided by a RED lamp. An external reset facility is provided.

Short Circuit Protection

Typically 250 A or 450 A HRC Fuse protection will be provided.

If thermal over current protection is fitted, suitably rated magnetic short circuit trips will be provided.

If electronic over current protection is fitted, short circuit protection of 6, 8 or 10 times the overload setting can be selected.

Short circuit protection can be either self resetting, or latching. Indication is provided by a RED lamp. An external reset facility is provided.

Earth Fault and Lockout Protection

Earth fault protection can be provided to meet most customer applications with trip levels available from 100 mA up to 5 A according to specification. Test facilities are provided.

For earth lockout, an insulation monitor is provided (earth lockout module) to give protection when the contactor is open. Lockout resistance to earth of 10 kilohm to 220 kilohm (level to be specified) will activate the protection device and prevent the closing of the contactor until the cause has been removed.

Indication is provided by a RED lamp. Test facilities are provided.

Once the reason for the trip has been removed the earth leakage and lockout system can be externally reset.

Ambient Temperature

The design is suitable for use in typical ambient temperatures minus 20°C up to plus 40°C.



Factory pre-assembled 6 x Panel Switchboard

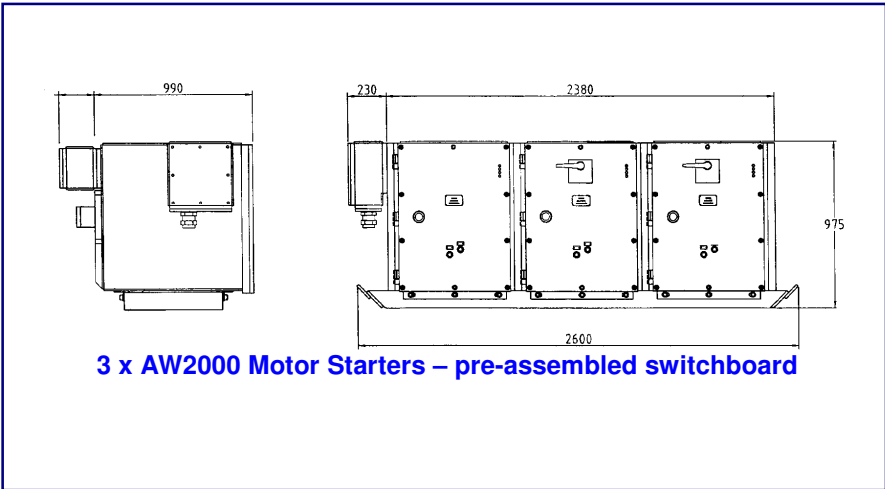
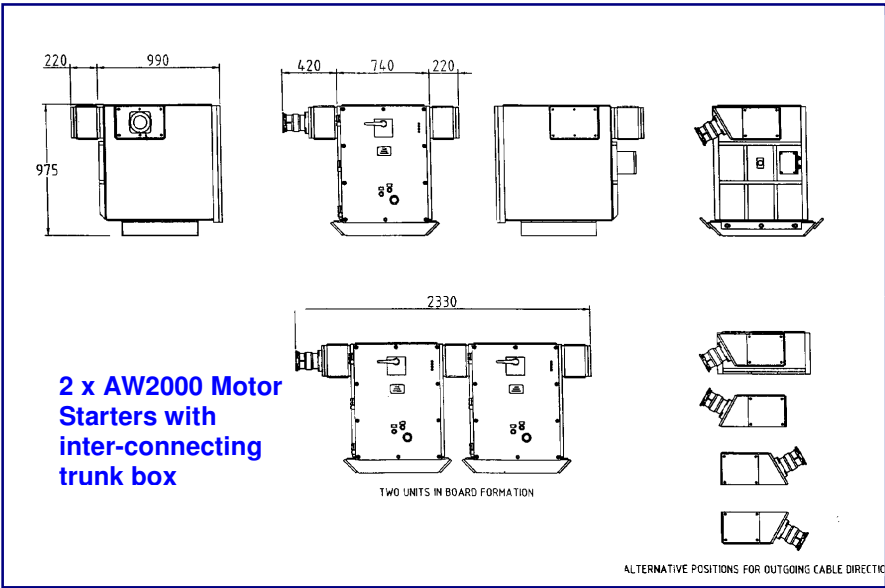
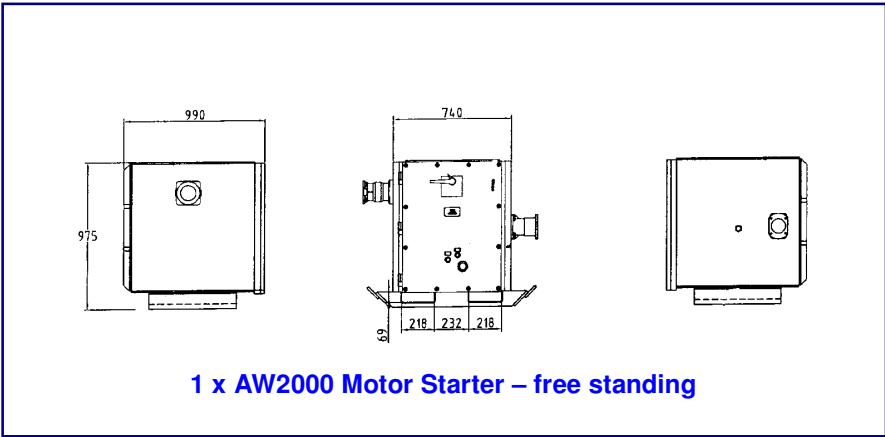

Trades Description Act

Due to our continuous development programme and the ever-changing requirements of British, European and International standards, it may prove necessary to alter the design or description of the equipment detailed in this publication without prior notice.

Details are typical and product specification may be varied to suit customers requirements



Ampcontrol Allenwest

66 Third Avenue
Heatherhouse Industrial Estate
Irvine KA12 8HN
United Kingdom

Tel 01294 273111 Fax 01294 274063

Email uksales@ampcontrolgroup.co.uk
Website www.ampcontrolgroup.co.uk



ISO 9001
Certificate No FM21000